



MIRRICO
GROUP OF COMPANIES

THE PROCESS ENGINEER'S HANDBOOK

SOLUTIONS FOR OIL
AND GAS REFINERY
AND PETROCHEMICAL
ENTREPRISES

THE PROCESS ENGINEER'S HANDBOOK

DEAR COLLEGUES,

The purpose of this book is to provide advisory support in solving typical problems that arise during chemical treatment operations in various industries.

The cases proposed by the experts of the Mirrico Group will enable you to act promptly, independently and correctly in eliminating deviations that may occur in certain types of reagent treatment at oil refineries and petrochemical enterprises. In addition, The Process Engineer's Handbook will help to delve deeply into the understanding of the tasks and principles of chemical treatment.

The Mirrico Group has been working in the field of oil and gas refining since 2010. During this time, the experts of the company have gained a considerable experience, having studied and eliminated a large number of complexities and irregular situations at oil refineries and petrochemical enterprises. Some of them are described in this book.

The Process Engineer's Handbook is designed for the personnel of the facilities where the chemical treatment is carried out: operators, plant managers, foremen, and all those who face chemical treatment issues on a daily basis, regulates the treatment process and monitors its efficiency.

**THE CASES HAVE BEEN
DRAWN UP BY PROCESS
ENGINEERS OF OIL
AND GAS REFINERY
AND PETROCHEMICAL
INDUSTRY BUSINESS
UNIT OF THE MIRRICO
GROUP (OSNOVA LLC
CHEMICAL GROUP)**



CONTENTS

Solutions for oil refineries

5	1.0. Reagents for the crude oil distillation plant	9	1.2.2. Brands of reagents
5	1.1. Reagents for crude desalter unit	9	1.2.3. Reagent feeding options
5	1.1.1. Reagents description	10	1.2.4. Possible Case solutions
5	1.1.2. Description of the reagents application	10	1.2.4.1. Case: Sharp decline in PH drainage water of reflux tanks of atmospheric columns down to 2-4 units.
6	1.1.3. Reagent feeding options	10	1.2.4.2. Case: Increase in pH of the drainage water is above normal values when the neutralizer pumps are running at minimum capacity
7	1.1.4. Possible case solutions	11	1.2.4.3. Case: Increase of iron content in drainage waters is higher than the specified values
7	1.1.4.1. Case: High water content in crude oil, trapped oil supply	11	1.2.4.4. Case: Corrosion of non-ferrous equipment
7	1.1.4.2. Case: Water content of desalted oil is above standard values	11	1.2.4.5. Case: Loss of chemical feed
7	1.1.4.3. Case: Concentration of chloride salts in desalted oil is above the standard values	12	2.0. Additives for diesel fuels
8	1.1.4.4. Case: Excessive content of petroleum products in the drainage water of crude desalter unit	12	2.1. Chemical description
8	1.1.4.5. Case: Short circuit (electrical breakdown) of electrodes	12	2.2. Ignition promoter (cetane improver additive)
8	1.1.4.6. Case: Loss of chemical feed	12	2.2.1. Additive description
9	1.2. Reagents for atmospheric distillation unit	12	2.3. Lubricity additive
9	1.2.1. Description of the reagents application	13	2.3.1. Additive description



13	2.4. Depressing and dispersing additive	16	3.4. Recommendations on dosing scheme
13	2.4.1. Description of the depressing and dispersing additive	17	3.5. Treatment control and regulation
14	2.5. Possible case solutions	17	3.6. Possible case solutions
14	2.5.1. Case: Low cetane value of the end product	17	3.6.1. Case: Excess of hydrogen sulfide content in the product under processing
14	2.5.2. Case: Reduction of the lubricity of the end product with regard to the nominal values	18	3.6.2. Case: Presence of water soluble acids and alkali in the processed product
14	2.5.3. Case: Downgrading of the cold filter plugging point or sedimentation stability of the end product compared to the specified values	18	3.6.3. Case: Reagent feeding defects
15	3.0. Hydrogen sulfide scavenger chemicals for petroleum products	19	4.0. Additives for medium distillates and fuel oils
15	3.1. Chemical description	19	4.1. PPD additive
15	3.2. Brands of reagents	19	4.1.1. Brands and grades of additives
16	3.3. Correct application scheme	19	4.1.2. Description of additive application
		20	4.1.3. Possible case solutions
		20	4.1.3.1. Case: Increasing the pour/congelation point of the end product with regard to the specified values

Solutions for the petrochemical enterprises

21	1.0. Reagents for monomers production	25	1.1.6. Solutions to possible issues with pyrolysis gas compressing unit
21	1.1. Heat polymerization inhibitors	25	1.1.6.1. Case: Polymers scaling on the walls of compressor equipment and blockage of interstage coolers
21	1.1.1. Chemical description		
21	1.1.2. Brands of reagents		
22	1.1.3. The scheme of correct usage (for a fractionating unit)	26	2.0. Solutions for ethylene production: pyrolysis gas alkali treatment unit
23	1.1.4. Possible case solutions	26	2.1. Aldehyde condensation inhibitor
23	1.1.4.1. Case: Frequent cleaning of filters to control polymer particles	26	2.1.1. Chemical description
23	1.1.4.2. Case: Increase of the heating agent consumption for the boiler	26	2.1.2. Brands of reagents
24	1.1.5. Solutions to possible issues in the manufacturing of styrene	26	2.1.3. Correct application scheme
24	1.1.5.1. Case: Blockage of packing nozzles in a styrene fractionating column	27	2.1.4. Possible case solutions
		27	2.1.4.1. Case: Increase of differential pressure in the column

SOLUTIONS FOR REFINERY

1

CHEMICALS FOR CRUDE OIL DISTILLATION PLANT

The primary oil distillation unit includes the following blocks:

- Crude desalter unit
- Atmospheric distillation unit for desalted oil
- Vacuum fuel oil distillation unit (normally, no reagent treatment applied in the vacuum column).

The Mirrico Group (Osnova LLC Chemical group) offers a package of reagents for demineralization and dehydration of crude oil, chemical and technological protection of condensation and refrigerating equipment from corrosion during atmospheric distillation of desalted oil and vacuum distillation of fuel oil.

1.1. Reagents for Crude desalter unit

1.1.1. Reagent description

Substandard efficiency of dehydration and desalination causes a number of problems at oil refineries:

- 1) corrosion of equipment;
- 2) increase of pressure in the K-1 column;
- 3) a significant increase in the costs of alkalizing agents;
- 4) excessive expenditures of such costly reagents as corrosion neutralizers and inhibitors;
- 5) in some cases- inability to provide the required efficiency of chemical and technological protection from corrosion.

The above-mentioned factors lead to reduction of the installation overhaul life, as well as to increase in the costs of its operation.

OR-1626, OR-1627 (A, B), OR-1628 Decleave demulsifiers of the Mirrico Group serve to help resolving these problems.

1.1.2. Description of the reagents application

The demulsifier is fed into the oil stream by the suction pump to increase the efficiency of desalting and dehydration of oil. The principle of the Decleave action is destruction of the inhibiting layer surrounding the drops of formation water, and preventing its formation around the drops of the scouring water newly supplied to the oil.



1

REAGENTS FOR CRUDE OIL DISTILLATION PLANT

1.1.3. Reagent feeding options

1. Reagent feeding on the suction pumps before the heat exchange unit (oil heating unit) in its market condition.

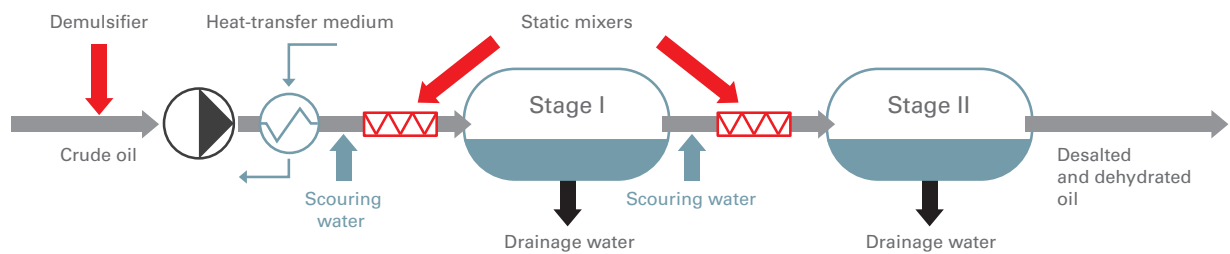

2. Reagent feeding to the crude desalter unit before the first stage of electric desalination in market condition.

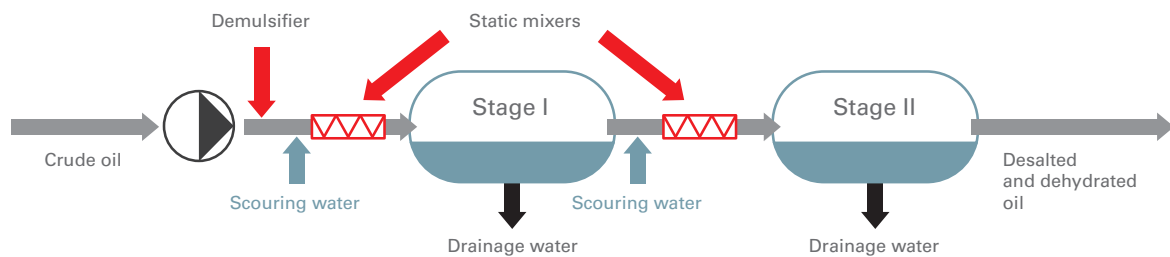

CHEMICALS FOR CRUDE OIL DISTILLATION PLANT

1.1.4. Possible case solutions

1.1.4.1. Case: High water content in crude oil, trapped oil supply

The high water content of the crude oil as well as the trapped oil pumping can lead to an increase in the emulsion layer in the electric dehydrator, which can cause overload of the electrodes (abrupt increase in voltage of the electrodes) and their failure. To prevent failure of electrodes and disruption of the dehydration and oil desalting process:

- 1) increase the drainage water discharge;
- 2) reduce the scouring water flow;
- 3) lower the pressure drop on the mixing vessel;
- 4) increase the demulsifier flow rate.

1.1.4.2. Case: Water content in the desalted oil is above standard values

High water content in desalted oil can lead to:

- 1) excessive load of steam in the stripping column, which would require large energy costs for steam condensation;
- 2) excessive content of chloride salts dissolved in water, which leads to intensification of hydrochloric corrosion.

Given a steady load in terms of raw materials and stable operation of electric dehydrators, it is required:

- 1) if you receive an unsatisfactory test result, first take a new sample to confirm or disprove the result;

2) in case if unsatisfactory analysis is confirmed:

- reduce the scouring water flow by 10-15% vol., if there is a second or third stage of desalination, first lower the water flow on the last stage;
- lower the pressure drop on the mixing vessel valves;
- temporarily increase the consumption of demulsifier by 30-35%;
- increase the discharge of drainage water, and prevent oil from entering the water phase;
- take new sample after 2-3 hours.

1.1.4.3. Case: Concentration of chloride salts in desalted oil is above standard values

To achieve the required degree of desalination, carry out the following procedures:

- 1) ensure an effective salts outwash from oil: increase the flow rate of water for each electric dehydrator. First, increase the flow rate of the scouring water to the first desalination stage. Then, if necessary, increase the water flow to the next stages;
- 2) ensure the intensification of mixing of oil and scouring water by controlling (increasing) the pressure drop across the mixing valves;
- 3) at low pH values of drainage water from the crude desalter unit (which may be the cause of poor desalination), increase the supply of alkali to raise the pH to 6.5-7.5 units. (if there is a scheme for crude oil alkalization);
- 4) ensure the water content in desalted oil is normal, if it exceeds the norm, see case 1.1.4.2 «Water content of the oil is above standard value».



1

CHEMICALS FOR CRUDE OIL DISTILLATION PLANT

1.1.4.4. Case: Excessive content of petroleum products in the Crude Desalter Unit drainage water

To prevent contamination of crude desalter unit drains with oil products, do the following:

- 1) reduce the discharge of drainage water by pressing a drain valve;
- 2) if the pH of drainage water is 8 units and above, reduce the supply of alkaline solution to crude oil (if the desalted oil is alkalized).

1.1.4.5. Case: Short circuit (Electrical breakdown) of electrodes

To prevent short circuits of the electrodes, proceed as follows:

- 1) maintain the optimal temperature of the desalting process. Excessive temperature rise can lead to an increase in the electric power consumed by the electrodes, which in turn can lead to breakdown of the electrodes;
- 2) with the help of drainage control valves, monitor the discharge of drainage water, also regulate the supply of scouring water to the electric dehydrator, ensuring balance between oil-emulsion-salt water phases and preventing electrodes from entering the zone with the excessive water phase content;
- 3) if thickness of the emulsion layer is high, act in accordance with case 2.1.2.1 «High water content in crude oil, trapped oil supply».

1.1.4.6. Case: Loss of chemical feed

In this situation, do the following:

- 1) check the operational capability and precision of the pump, calibrate the pump;
- 2) if the pump(s) are inoperative, first check the status of the filter set on the receiving pipe of the pump(s); if necessary, rinse the filter with hot water;
- 3) if there is no chemical suction while the filter condition is normal, perform an inspection of the respective pump(s) and fix the existing problems.



1

CHEMICALS FOR CRUDE OIL DISTILLATION PLANT

1.2. Reagents for atmospheric distillation unit

1.2.1. Description of the reagents application

After the crude desalter unit, desalted and dehydrated oil passes through the heat exchange unit and goes to the atmospheric distillation unit to produce light oil products.

To protect the still-head pipes of distillation columns and condensation and refrigeration equipment from the corrosive effects of hydrogen chloride and hydrogen sulfide, an alkaline solution is applied to the desalted oil line, a neutralizer and a corrosion inhibitor are applied to the still-head pipes using dosing pumps.

Neutralizers are used to neutralize aggressive components of the process media and to smoothly adjust the pH of drainage water in reflux containers.

Corrosion inhibitors are designed to prevent the metals of the equipment from being exposed to aggressive components of process media, such as H₂S, HCl, by creating a protective film on the metal surface due to physical and chemical adsorption.

1.2.2. Brands of Reagents

Applied neutralizers of the Mirrico Group: Scimol OR-1001, OR-1002, OR-1004. Applied corrosion inhibitors of the Mirrico Group: Scimol OR-2001, OR-2003, OR-2004.

1.2.3. Reagent feeding options

Feeding scheme:

1) in market condition with subsequent mixing with transporting medium (straight-run gasoline fraction);

2) in market condition without a transporting medium;
3) in a diluted form, the solution is prepared in advance (dilutents: straight-run gasoline, kerosene fraction, water).

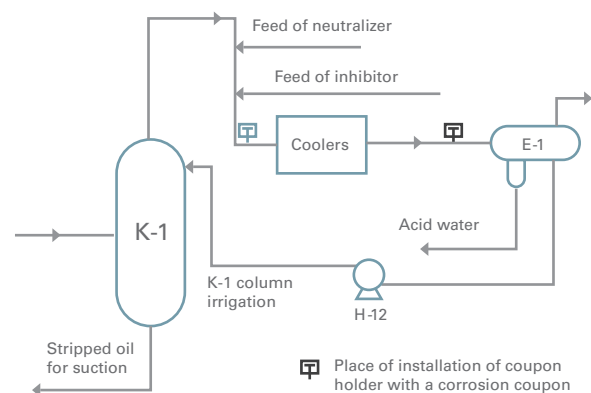
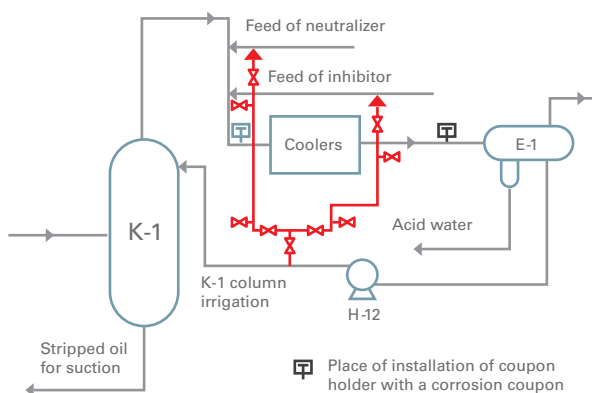

1

CHEMICALS FOR CRUDE OIL DISTILLATION PLANT

1.2.4. Possible case solutions

1.2.4.1. Case: Sharp decline in PH of atmospheric columns reflux reservoirs drain water down to 2-4 units.

The reasons for a sharp fall in the hydrogen index can be:

- 1) high concentration of chloride salts in desalted oil. In this case, the amount of alkali supplied is usually insufficient for effective alkalization, also the chloride content in reflux containers drainage water increases;
- 2) high content of organic chlorine ion in crude oil or pumped products for processing;
- 3) supply of insufficient quantities of alkali in desalted oil.

To implement right correcting measures in the medium term, it is necessary to clearly identify the cause of such a fall:

- 1) perform several additional tests of the contents of chloride salts in the CDU feedstock (desalted oil). If tests show poor desalination, adjust the work of the Crude Desalter Unit (see cases «Reagents of the Crude Desalter Unit»);
- 2) determine the content of organochlorine compounds in the CDU feedstock and in gasoline from reflux containers. It is necessary to exclude the processing of oil and feedstocks with a high content of organochlorine compounds;
- 3) check the accuracy of alkali dosing, including the concentration of alkaline solution, adjust if deviations are detected.

Before detecting the reasons for the pH drop (and their elimination), it is necessary to promptly fix the situation:

- 1) perform a re-sampling of drainage water of reflux containers and promptly verify that the deviation remains (pH at the level of 2-4.5 units);
- 2) Increase the alkali charge until the pH of the water in the drainage vessels of the columns increases to a minimum of 5.0 units and reduce the chloride content to less than 25 mg / l (preferably);
- 3) use the neutralizer for further increase in pH of drainage waters to the specified values

1.2.4.2. Case: Increase in pH of drainage waters above the standard when neutralizer feed pumps operate at minimum capacity

Recommended actions in this situation:

- 1) turn off the neutralizer feed for a short term, as pH in the drainage waters will be supported by effective alkalization;
- 2) if pH is still above normal, reduce the alkali feed.



CHEMICALS FOR CRUDE OIL DISTILLATION PLANT

1.2.4.3. Case: Increase in the iron content of drainage waters above the specified values

The content of iron ions in the drainage waters of reflux containers usually directly depends on the accuracy of maintaining the properly selected pH range. Significant deviations of pH from the normal to the acid values result in flushing of inhibitory and sulfide film, while the iron content in the drainage waters increases dramatically and the effectiveness of the chemical-engineering protection drops.

When an unsatisfactory test result on the content of iron in the drainage waters of the reflux containers is obtained:

- 1) take a new sample again for analysis (detect the content of the iron ions, chloride, pH) and assess visually the quality of the water by color;
- 2) given a low pH value (less than 5.5 units) and high chloride content (more than 25 mg/dm³) in the drainage waters of the reflux container, the following is recommended:
 - increase the alkali charge in desalted oil until pH values reach more than 5.5 units and chlorides do not exceed 25 mg/dm³;
 - increase the neutralizer charge to increase pH to optimum values (to be determined individually);
 - in the event of a failure to reach the normalized iron content values, increase the corrosion inhibitor charge (in steps, one time by 20%, waiting for a response from the system within 1-2 days);
- 3) in some cases, the increased iron content is associated with the detergent power of the corrosion inhibitor. To test this theory, reduce the feed of the inhibitor and check the system response within two days.

1.2.4.4. Case: Corrosion of non-ferrous metal equipment

The tube packs of refrigerant condensers made of non-ferrous metals (copper and zinc alloys) are subject to corrosion cracking in the medium with pH above 8-9 units and in the presence of ammonia.

The following is recommended when detecting the corrosion of non-ferrous metals above the norm:

- 1) strictly maintain pH range in the reflux containers at a level not exceeding 6.5 units;
- 2) increase the dosage of the corrosion inhibitor;
- 3) to monitor the corrosion of the production equipment made of non-ferrous metals, periodically control the content of zinc and copper ions in the drainage waters, and set the coupons made of appropriate material.

1.2.4.5. Case: Loss of chemical feed

In this situation, it is necessary:

- 1) check the performance and feed accuracy by the appropriate pump(s) of the alkali solution and the neutralizer and calibrate it;
- 2) if the pump(s) are inoperative, first check the status of the filter set on the receiving pipe of the pump(s); if necessary, rinse the filter with hot water;
- 3) if there is no chemical and the filter condition is normal, perform an inspection of the respective pump(s) and fix the existing problems.

In the period following the drop of pH of the drainage waters in the reflux containers below 5 units, as well as in the event of change of the corrosion inhibitor, a jump in the iron content for several days is possible.



DIESEL-FUEL ADDITIVES

2.1. Additive description

The Mirrico Group additives package is designed for improvement of the performance characteristics of diesel fuel (DF) to the requirements of the standard technical documentation. The package includes:

- cetane improver additives;
- lubricity additives;
- additives improving low-temperature characteristics of diesel fuels (CFPP additives).

2.2. Cetane improver additives

The cetane number influences the important aspects of the engine performance: start, mean effective combustion pressure, specific fuel consumption, exhaust gas temperature, engine sediment, smokiness and odor of combustion gases.

With the increase in the cetane number of fuels, it is easier to start the engine and the mean combustion pressure increases, the remaining indicators decrease, and the engine running generally improves.

2.2.1. Additive description

The cetane improver additive Atrén Cet by the Mirrico Group is fed in a diesel fuel flow to bring the cetane value to the specified values. The cetane improver additive (a product based on 2-ethylhexylnitrate) allows decreasing the delay period in the fuel blend self-ignition. The cetane improver additives act in the early stages of the combustion process due to easy molecular decomposition into active radicals and initiation of ignition.

The amount of the additive required to obtain the diesel fuel with the specified cetane number depends on the quality (fractional and group composition), the number of diesel fuel components, and the required cetane number and is determined in the laboratory tests of the additive.

2.3. Lubricity additive

Many heteroatomic compounds, which are potentially part of the diesel fraction, including those sulphur-bearing, are surface-active substances capable of to create a protective film on the surface the metal. Recently, the standards for sulphur content in fuels have been significantly tightened, resulting in the deterioration of fuel lubricity, which, in turn, causes a negative impact on the elements of the fuel system.

When using DF with below-average sulphur, it is not possible to provide the necessary fuel lubricity without using the appropriate additives. In order to prevent the deterioration of the parts of the diesel fuel system, the lubricity additives are applied.

2.3.1. Additive description

Lubricity additive Atrén Lub by the Mirrico Group is fed in the diesel fuel components flow to increase the lubricity. The lubricity additive is a substance of organic origin, which is based on fatty acids or ethers of fatty acids. The mechanism of the wear-proof additives action consists in the formation of a modified layer of metal that ensures a smooth load distribution and reducing wear, resulting from the chemical interaction of the additive with fine films of oxides on the wearing surfaces.

The amount of the additive required to obtain the diesel fuel with the specified wear-preventive properties depends on the quality (fractional and group composition) and the number of diesel fuel components, and it is determined in the laboratory tests of the additive.

2.4. CFPP additive

Improving the low-temperature properties of diesel fuels is of great practical relevance to the climate of Russia. One of the most cost-effective ways of regulating the low-temperature properties of different classes and grades of diesel fuel is application of CFPP additives.

The purpose of these additives is to lower the fuel pour point and the cold filter plugging point, to increase the sedimentation stability of diesel fuels.

2.4.1. Additive description

CFPP additives additive Dewaxol™ (grades 2001 C and K, 2002 C and K, 2003 C and K) by the Mirrico Group is fed in the diesel fuel flow to decrease the maximum filtration temperature and to prevent sedimentation (fuel separation) in cold storage. The CFPP additives additive is a substance of organic origin, consisting of two components: the depressing component, which is a copolymer responsible for decreasing the maximum filtration temperature and the pour point of the diesel fuel, and the dispersing component, which is a nitrogen-containing organic substance preventing the consolidation of crystallizing components of fuels into large aggregates when the temperature of n-paraffins is decreasing and thus contributing to the preservation of the aggregative stability of the diesel fuel at temperatures below the cloud temperature.

The amount of the additive required to obtain the diesel fuel with the specified low-temperature properties depends on the quality (fractional and group composition, molar mass distribution of paraffins) and the number of diesel fuel components, and it is determined in the laboratory tests of the additive.



2.5. Possible case solutions

2.5.1. Case: Low cetane value of finished product

If there are problems with the low cetane number of the diesel fuel in the standard operating dosages of the cetane improver additive, follow these steps:

- 1) check the feeding equipment operability and the accuracy of the additive dosing;
- 2) check the quality of the original diesel fuel (quantity and quality of the involved diesel fuel components, the original cetane number);
- 3) if necessary, increase the cetane improver additive charge by presetting the effective dosage in the lab.

2.5.2. Case: Reduction of the lubricity of the finished product compared to the specified values

The lubricity of diesel fuels depends on the content of heteroatomic compounds, including sulphur-containing, as well as the hydrocarbon ratio of the various classes in the fuel. The lubricity also depends on the cetane improver additive. In the case of reduction of the lubricity of the diesel fuel compared to the values specified in standard work dosages of lubricity (wear-proof) additive, follow these steps:

- 1) check the feeding equipment operability and the accuracy of the additive dosing;
- 2) check the quality of the original diesel fuel (quantity and quality of the involved diesel fuel components, lubricity of the original fuel);
- 3) check whether the involvement of the cetane improver additive has increased, causing a negative impact on the lubricity of the fuel;
- 4) if necessary, increase the lubricity additive charge by presetting an effective dosage in the lab.

2.5.3. Case: Downgrading of the cold filter plugging point or sedimentation stability of the finished product compared to the specified values

The main factor influencing the effectiveness of the depressing and dispersing additive is the molar mass distribution of paraffins in the diesel fuel. The lubricity additive also can influence the depressing and dispersing additive effectiveness. If the low-temperature properties of the end diesel fuel deteriorate, follow these steps:

- 1) check the metering equipment operability and the accuracy of the additive dosing, homogeneity of the work solution in the dosing container (in case of additive solution dosing);
- 2) check whether the fuel formulation change has occurred (define: quantity and quality of the involved diesel fuel components; molar mass distribution of paraffins and compare it to the previous ones; the cloud temperature and cold filter plugging point of the fuel without additives);
- 3) in laboratory conditions, test the effectiveness of the depressing and dispersing additive on composite diesel fuel without the lubricity and cetane improver additives and with them with existing dosages;
- 4) if necessary, increase the CFPP additives charge by presetting an effective dosage in the lab.

HYDROGEN SULFIDE SCAVENGER CHEMICALS FOR PETROLEUM PRODUCTS

3.1. Chemical description

Asulpher™ is a range of chemicals by the Mirrico Group designed for control of hydrogen sulfide and mercaptans in petroleum refinery products, in light and dark oil products and the gas condensate. Asulpher™ helps to reduce the hydrogen sulfide content in fuel oil to the level of:

- not more than 2 ppm, according to the requirements to the quality of exported fuel oil.



OPU-30 LLC is the Mirrico Group's own plant with productive capacity up to 3,000 tones

3.2. Brands of reagents

All Asulpher reagent brands have a high absorbing capacity for hydrogen sulfide, without adverse affect on the quality of the oil products. The absorbing capacity for mercaptans varies depending on the reagent brand. The reagent brand is selected individually for each specific process task based on the results of laboratory testing or on the basis of the experience of the Mirrico Group experts, taking into account the technological characteristics of production and requirements of the customer.

Asulpher 7001, 7003, 7004, 7006, 7009, 7010, 7002B are the chemicals based on nitrogen and oxygen containing compounds (mixture of amines, aldehydes, triazines, carbamide, urotropine, etc.) and are highly effective even in low dosages.

Asulpher 6002, 6501, 6504 are triazine-based chemicals, that have a high absorbing capacity not only towards hydrogen sulfide, but also to mercaptans.

Asulpher 7002A, 7005 are urotropine-based chemicals of the hazard class 4.

Asulpher K-A is a catalyst for oxidation of hydrogen sulfide and mercaptans.



3

HYDROGEN SULFIDE SCAVENGER CHEMICALS FOR PETROLEUM PRODUCTS

3.3. Correct application scheme

Asulpher hydrogen sulphide scavenger is designed for continuous or periodic dosing from the storage

vessel to a pipeline of the processed medium (mixed fuel oil, cracked residue, tar, etc.) using the metering equipment. The following figure shows one of the options for the scavenger dosing scheme.

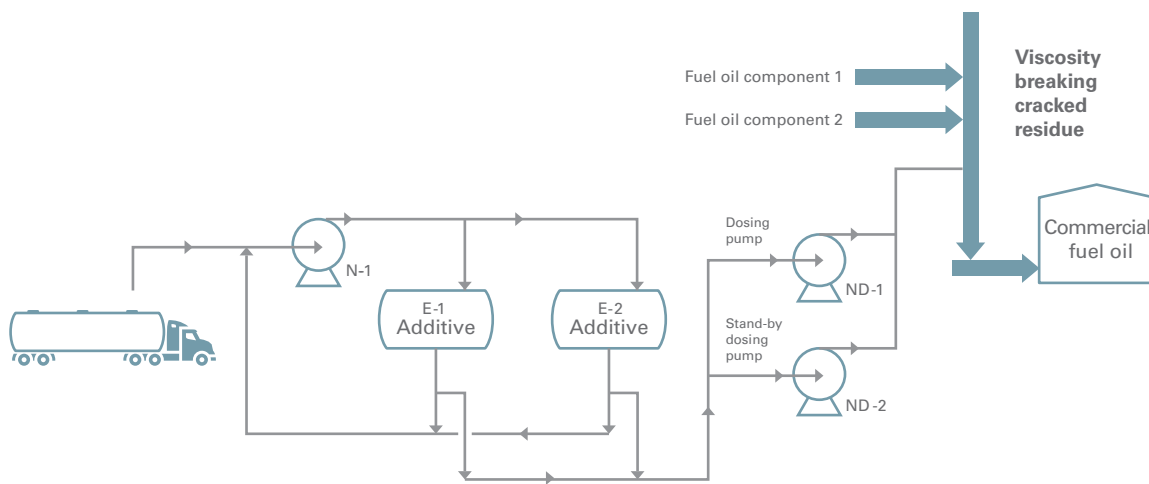

3.4. Recommendations for the dosing scheme

It is recommended:

- 1) the additive injection point should be removed from the commercial tanks as far as possible to increase the reaction time of the chemical with hydrogen sulphide;
- 2) to feed the chemical to the mixed fuel oil line more accurately after mixing of all hydrogen sulfide containing components;
- 3) the range of temperatures at the chemical injection point is 60 to 130 °C;
- 4) application of a mixing device of the static mixer type after the chemical injection point.

The dosage of the chemical is calculated based on the processed product charge and the original content of hydrogen sulfide in it, according to the formula:

$$Q_{\text{chemical}} = \frac{Q_{\text{fuel oil}} \cdot D \cdot N_{\text{H}_2\text{S}}}{10^3 \cdot \rho_{\text{chemical}}}$$

Q_{chemical} is the chemical charge [l/h];
 D is the effective dosage of the chemical, determined in the course of the pilot testing [ppm of scavenger: hydrogen sulfide ppm in the original fuel oil];
 $N_{\text{H}_2\text{S}}$ is quantity of hydrogen sulfide in the original fuel oil, ppm;
 ρ_{chemical} is density of hydrogen sulfide scavengers [g/cm³];
 Q is the processed fuel oil charge, t/h.

HYDROGEN SULPHIDE SCAVENGER CHEMICALS FOR PETROLEUM PRODUCTS

3.5. Treatment Control and Regulation

Analytical control of the treatment results includes detecting the hydrogen sulfide content in oil fuel (or its separate components) according to the IP 399/94 method:

- before the involvement of additives;
- after the involvement (in the process line);
- in commercial tanks when they are filled and during the certification.

Depending on the results of the analytical control the reagent feeding is modified upwards or downwards.

The reagents are delivered in tank trucks or in closed containers (200 liter barrels or IBC eurocubes).

When the storage volumes and pipelines are filled with hydrogen sulfide scavenger, drainage of the feeding unit and its cleaning (for example, steam treatment) from the previously used reagent must be performed.

3.6. Possible case solutions

3.6.1. Case: Excess of hydrogen sulfide content in the product under treatment

In the case of hydrogen sulfide content in commercial fuel oil exceeds the normal amount, the following is recommended:

- 1) check that dispensing pumps are functioning correctly, and the regularity of reagent consumption, by observing the reagent level decrease in the storage tank, calibrating the pumps or by using other available means;
- 2) recollect the petroleum product samples and repeat the test;
- 3) evaluate the quality of the raw product by its hydrogen sulfide content: perform the tests of the initial mixed fuel oil, fuel oil components, analyse the mixed fuel oil formulation for any change in the equivalence ratio of components with hydrogen sulfide;
- 4) increase the consumption of the hydrogen sulfide scavenger, with the increase ratio determined by the resulting excess level of hydrogen sulfide;
- 5) when feeding Asulpher™ of the K-A brand make sure that the air supply to the product treatment line is stable and sufficient, and increase the air consumption if necessary;
- 6) in the event of the repeated excess of the hydrogen sulfide scavenger dosage with regard to the specified norms of consumption please contact a Mirrico Group representative.



3

HYDROGEN SULFIDE SCAVENGER CHEMICALS FOR PETROLEUM PRODUCTS

3.6.2. Case: Presence of water soluble acids and alkali in the processed product

In the event of unsatisfactory test results on water soluble acids and alkali in fuel oil the following is recommended:

- 1) calibrate the pH tester. Repeat the test on water soluble acids and alkali content in fuel oil on both the previous sample and the new sample;
- 2) determine the pH value of the water extract of fuel oil from the process line before and after treating it with hydrogen sulfide scavenger to eliminate the negative impact of the reagent. Also for this purpose, a laboratory test of the hydrogen sulfide scavenger sample can be taken on the current material with the highest possible values of commercial grade dosages;
- 3) determine the pH value of the water extract of the primary components of fuel oil. If the water soluble acids and alkali occur in the fuel oil regularly, then it is necessary to perform such tests more than one time.
- 4) take the alkalization test using the enterprise's CDU units: overdosage control for the alkaline solution, feeding optimization.

3.6.3. Case: Reagent feeding defects

Decrease in the efficiency of treatment may be caused by a malfunction of the dosing equipment, which may lead to insufficient feeding of the scavenger into the petroleum product. The following is recommended:

- 1) check the working capacity and feeding accuracy of the relevant pump and calibrate it if necessary;
- 2) if any non-operability of the pump is detected, primarily check the condition of the filter installed on the intake pipe (if any), wash the filter if necessary;
- 3) check the lines and the fittings of the reagent feed circuit for flowing ability;
- 4) if there is no chemical and the filter condition is normal, perform an inspection of the respective pump(s) and fix the existing problems, check airtightness, check the valves for normal operation.



ADDITIVES AGENTS FOR MEDIUM DISTILLATES AND FUEL OILS

4.1. PPD additive

If the temperature in medium distillates and fuel oils decreases, wax crystals begin to form at an intensive rate. These crystals form a frame, which leads to loss of fluidity. One of the most economically viable means of reducing the pour/congelation point and improving the flow properties of the pumped/transported medium distillates and fuel oils is the use of PPD additive.

The operating principle of the PPD additive is based on the adsorption of the PPD additive molecules on the surface of the formed wax crystals with the simultaneous reduction of temperature, which prevents further growth of the crystals. Due to that, the wax crystals do not coarsen, the gel formation/thickening is reduced, the flow temperature and the congelation point of the petroleum product are decreased.

4.1.1. Brands and Grades of Additives

Additive:

- Dewaxol™ grade 7801;
- Dewaxol™ grade 7802;
- Dewaxol™ grades 7803A and 7803B;
- Dewaxol™ grade 7804;
- Dewaxol™ grades 7325-H and 7325-M;

The PPD additive is basically a set of custom made compositions based on surfactant reagents and copolymers in hydrocarbon solvent.

4.1.2. Description of Additive Application

The additive can be used in concentrated form when heated to the temperature of 50-70 °C, as well as in the form of solutions in diesel oil cut (or other hydrocarbon solvents) heated to the temperature of 40-50 °C. The additive is injected into a hot (over 60 °C) flow of the petroleum product under treatment.

Note: the lowest required temperature of the petroleum product under treatment is determined by the fusing temperature of waxes included in it, as well as the possibilities of providing effective mixing of the fuel with the additive (availability of mixing machinery, viscosity of the petroleum product at the temperature of the additive injection). Additive dosages have a sufficiently wide range (100-2000 g/t) and depend on the particle size and the group composition of the product under treatment, namely on molecular mass distribution of waxes and their quantity in the petroleum product. The effective dosages are determined by laboratory tests and pilot tests.



4

ADDITIVES AGENTS FOR MEDIUM DISTILLATES AND FUEL OILS

4.1.3. Possible case solutions

4.1.3.1. Case: Increasing the pour/congelation point of the end product with regard to the specified values

The main factors that influence the efficiency of the depressing agent are the particle size and the group composition of the under processing, as well as the molecular mass distribution of waxes and their quantity in the product.

If the low temperature properties of the finished fuel deteriorate (the required results for the low temperature properties are not achieved), perform the following actions:

- 1) check the metering equipment operability and the accuracy of the additive dosing, homogeneity of the work solution in the dosing container (in the case of additive solution dosing);
- 2) check the efficiency of the operational dosage of the additive in a laboratory, at the current base (the feedstock, before injecting the additive), as well as at the previous base (one where no problems on achieving the required depression for the operational dosage were experienced). This test will help to determine the problem: the quality of the feedstock or the quality of the additive batch;

- 3) in case if the cause is in the «base», check whether the formulation of the fuel was changed (determine: the quantity and the quality of the committed components of the end fuel; molecular mass distribution of waxes and compare it to such before; the pour/congelation point for the fuel without additives), make amendments in the formulation, if possible and viable;
- 4) if necessary, increase the depressive agent consumption by presetting an effective dosage in the lab.



SOLUTIONS FOR PETROCHEMICAL ENTREPRISES

1

REAGENTS FOR MONOMERS PRODUCTION

1.1. Heat polymerization inhibitors

1.1.1. Chemical description

The Mirrico Group's Dewaxol and InFlow heat polymerization inhibitors are basically compositions of heterocyclic compounds and are designed for suppressing processes of heat polymerization when producing basic monomers: ethylene, propylene, butadiene, isoprene and styrole.

The mechanism of inhibition is based on the binding of free radicals formed and the breakage of growing chains. The use of this type of reagents significantly increases the durability of column, heat exchange and compressing equipment that operates under high temperatures and high concentration of unsaturated hydrocarbons.

1.1.2. Brands of reagents

Dewaxol™ grades 3002, 3102 and InFlow™ grade 3002, 3102 for streams that contain butadiene and isoprene. Dewaxol™ thermal polymerization inhibitors grade 3004 and InFlow™ grade 3004 for the streams that contain styrol. Dewaxol™ brand 3003 and InFlow™ brand 3003 for manufacturing of butadiene and ethylene compressing units.



MIRRICO
GROUP OF COMPANIES

www.mirrico.ru

THE PROCESS ENGINEER'S HANDBOOK
SOLUTIONS FOR OIL AND GAS REFINERY
AND PETROCHEMICAL ENTREPRISES

21

1

REAGENTS FOR MONOMERS PRODUCTION

1.1.3. The scheme of correct usage (for a fractionating unit)

The choice of the inhibitor feed point is made according to the typical circuits on the basis of existing

problems with polymer sediments. When selecting the inhibitor feed point it is also necessary to understand the influence of the inhibitor on the following stages of production.

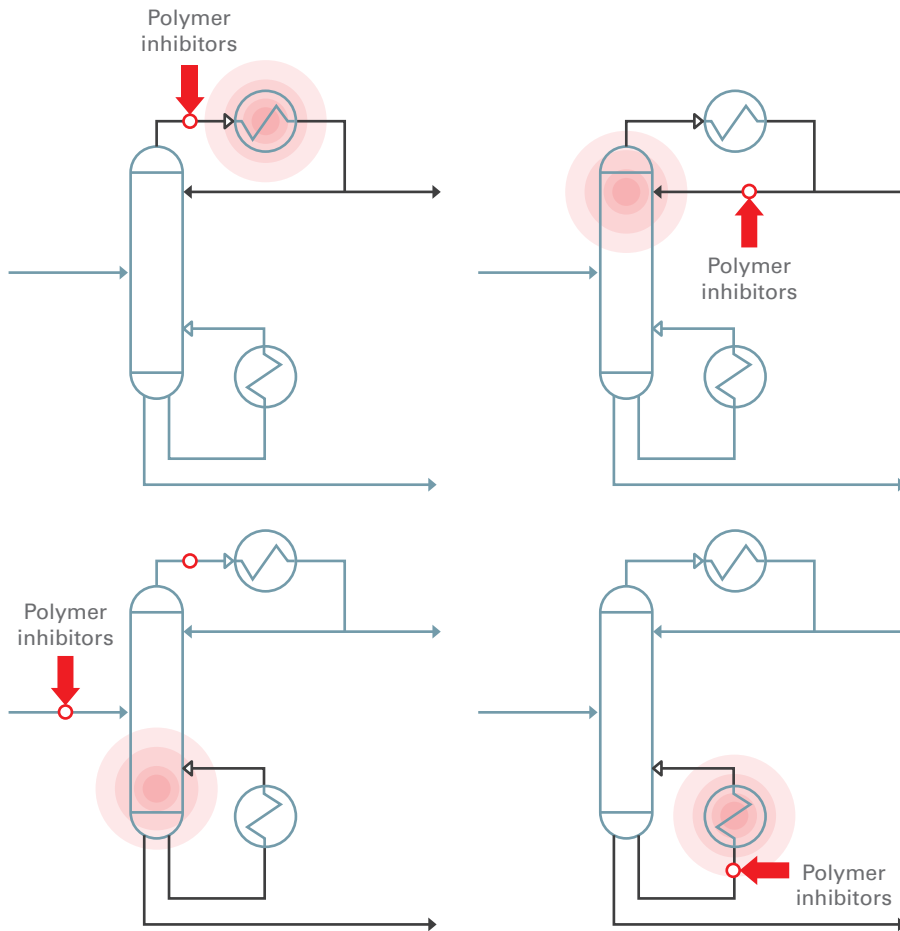

1

REAGENTS FOR MONOMERS PRODUCTION

1.1.4. Possible case solutions

1.1.4.1. Cases: Frequent cleaning of filters to control polymer particles

Frequent cleaning of filters to control polymer particles and the large amount of polymer sediments in filter baskets may indicate underinhibiting or the increase of operating temperature of the bottom of the column. Perform the following actions:

- 1) increase the inhibitor consumption to the approved consumption rates;
- 2) reduce the operating temperature of the bottom of the column to the standard values.

1.1.4.2. Case: Increase of the heating agent consumption for the boiler

The increase of the heating agent consumption for the boiler may indirectly indicate the formation of polymer sediments in the boiler pipes. To prevent this, perform the following actions:

- 1) check the load of the column in terms of feed and wet reflux. If possible, reduce the wet reflux consumption;
- 2) if the heating agent increase leads to the reduction of the bottom of the column temperature with the load being stable, then it is necessary to prepare a reserve boiler. After achieving the highest possible consumption rates for the heating agent and the reduction of temperature below the standard value, switch to the reserve boiler;
- 3) if the boiler duration turns out lower than average, report that to the technological service of the Mirrico Group and record the results of the boiler examination.



1

REAGENTS FOR MONOMERS PRODUCTION

1.1.5. Solutions to possible issues in the manufacturing of styrene

1.1.5.1. Case: Blockage of packing nozzles in a styrene fractionating column

The increase in the pressure difference across the column and the deterioration of the separation process may indicate the fractionating column blockage by polymer settlings. All this leads to a decrease in capacity of the commercial styrene facility. The formation of a polymer is possible in a few cases, but the most likely are:

- Low efficiency or low consumption of polymerization inhibitor;

Perform the following actions:

- 1) conduct an analysis of the inhibitor content in the bottom stream of the column;
- 2) in case of insufficient amount of inhibitor, increase the inhibitor's consumption;
- 3) report the increase in pressure difference across the column to the technological service of the Oil and Gas Refinery and Petrochemical Industry Business Unit of the Mirrico Group.

- Emergency shut-downs took place.

In order to prevent the polymerization of styrene during an emergency shut-down, it is necessary to comply with the following procedure during emergency power outages:

- 1) stop steam supply to the column evaporators. Monitor the temperature and prevent it from increasing sharply in the column;
- 2) stop power supply to the columns;
- 3) ensure that the inhibitor is supplied to the columns;
- 4) filling the columns with ethylbenzene;
- 5) drain ethylbenzene from the columns into the reserve tank;
- 6) after the columns are completely discharged, blow the columns clean with nitrogen.

1

REAGENTS FOR MONOMERS PRODUCTION

1.1.6. Solutions to possible issues with pyrolysis gas compressing unit

1.1.6.1. Case: Polymers scaling on the walls of compressor equipment and blockage of interstage coolers

The pressure difference increases across the interstage coolers, the increase in pressure and the temperature at discharge, may indicate the plugging of the heat exchange equipment with polymer scale. The following activities should be carried out:

- 1) increase the consumption of the thermal polymerization inhibitor feed with detergent effect on the suction of compressors;
- 2) increase the consumption of polymerization inhibitor in the pyrolysis gas pipeline before interstage cooler;
- 3) increase the consumption of flushing liquid (kerosene, BTX, etc.) on the suction of compressors;
- 4) contact the technological service of the Oil and Gas Refinery and Petrochemical Industry Business Unit of the Mirrico Group.



2

SOLUTIONS FOR ETHYLENE PRODUCTION: PYROLYSIS GAS ALKALI TREATMENT UNIT

2.1. Aldehyde condensation inhibitor

2.1.1. Chemical description

Pyrolysis gas alkali treatment units often have problems with the formation of the so-called «yellow oil», that leads to fouling of contact devices, foam formation and increased hydraulic resistance of the columns. Yellow oil is nothing more than a product of acetic aldehyde condensation. Acetic aldehyde is brought to the caustic wash tower together with the pyrolysis gas and is easily polymerized in the presence of alkali.

For protection against «yellow oil», we use special aldehyde condensation inhibitors that interact with aldehyde to form harmless products that are easily soluble in water.

2.1.2. Brands of Reagents

Dewaxol grade 3001-A, B, InFlow grade 3001-A, B.

2.1.3. Correct application scheme

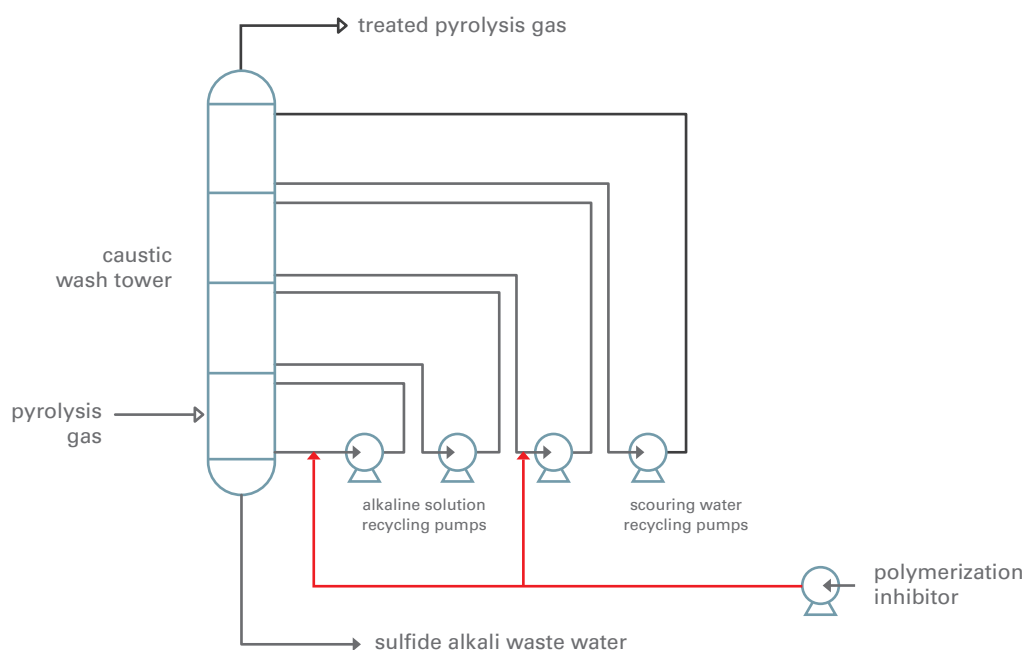

2

SOLUTIONS FOR ETHYLENE PRODUCTION: PYROLYSIS GAS ALKALI TREATMENT UNIT

2.1.4. Possible case solutions

2.1.4.1. Cases: Increase of differential pressure in the column

The increase of differential pressure may indicate the contact devices fouling with resins. Perform the following actions:

- 1) determine the acetic aldehyde content in the pyrolysis gas at the entry point in the column. If the value is higher than usual, increase the reagent feed;
- 2) if the differential is still high, feed pyrolysis resin or pyrolysis gasoline into the column to wash out the resins;

- 3) remaining high differential after the washing of the resins may indicate salt sediments on contact devices. In such a case perform the cleaning of the column by a steam condensate (water);
- 4) if the performed measures have not led to the reduction of the pressure differential in the column, report that to the technological service of the Mirrico Group of Companies.



ABOUT THE COMPANY

OIL AND GAS REFINERY AND PETROCHEMICAL INDUSTRY BUSINESS UNIT –

is the Mirrico Group's subdivision responsible for the domain of designing and adoption of advanced technologies and chemistry solutions to ensure technological and economic efficiency of the processes of oil and gas refining, as well as petrochemical processes.

The Mirrico Group's OGR & PI business unit develops and performs the following services:

- supplying reagents in order to improve the quality of light and heavy petroleum products, as well as to ensure continuous and failure-proof operation of the main technological processes of oil and gas refineries and petrochemical industry;
- selection, adoption, supply and regular monitoring of the reagents' efficiency for primary and secondary processes of oil refining.

**THE COMPANY
GUARANTEES HIGH
EFFICIENCY OF THE
PROPOSED CHEMICAL
REAGENTS, AS WELL
AS THEIR COMPLIANCE
WITH THE TECHNOLOGICAL,
ENVIRONMENTAL
AND ECONOMICAL
REQUIREMENTS
OF THE CUSTOMER.**



YOUR ADVANTAGES WHEN COOPERATING WITH THE MIRRICO GROUP'S OGR & PI BU:

- ensuring high efficiency of reagents for various processes of oil refinery and petrochemical industry;
- the economic effect as a result of high quality selection of OGR & PI reagents which manifests in both the reduction of the reagents cost, and the optimization of technological parameters of the main process, which results in reduction of maintenance operations cost and in the increased time between repairs;
- high level of service support, integration into a system of economical guarantees when using the OGR & PI BU products.

**FOCUS ON THE RESULT,
WE DO THE CHEMISTRY**



MIRRICO
GROUP OF COMPANIES

www.mirrico.ru

THE PROCESS ENGINEER'S HANDBOOK
SOLUTIONS FOR OIL AND GAS REFINERY
AND PETROCHEMICAL ENTREPRISES

29

BUSINESS DOMAINS OF THE MIRRICO GROUP

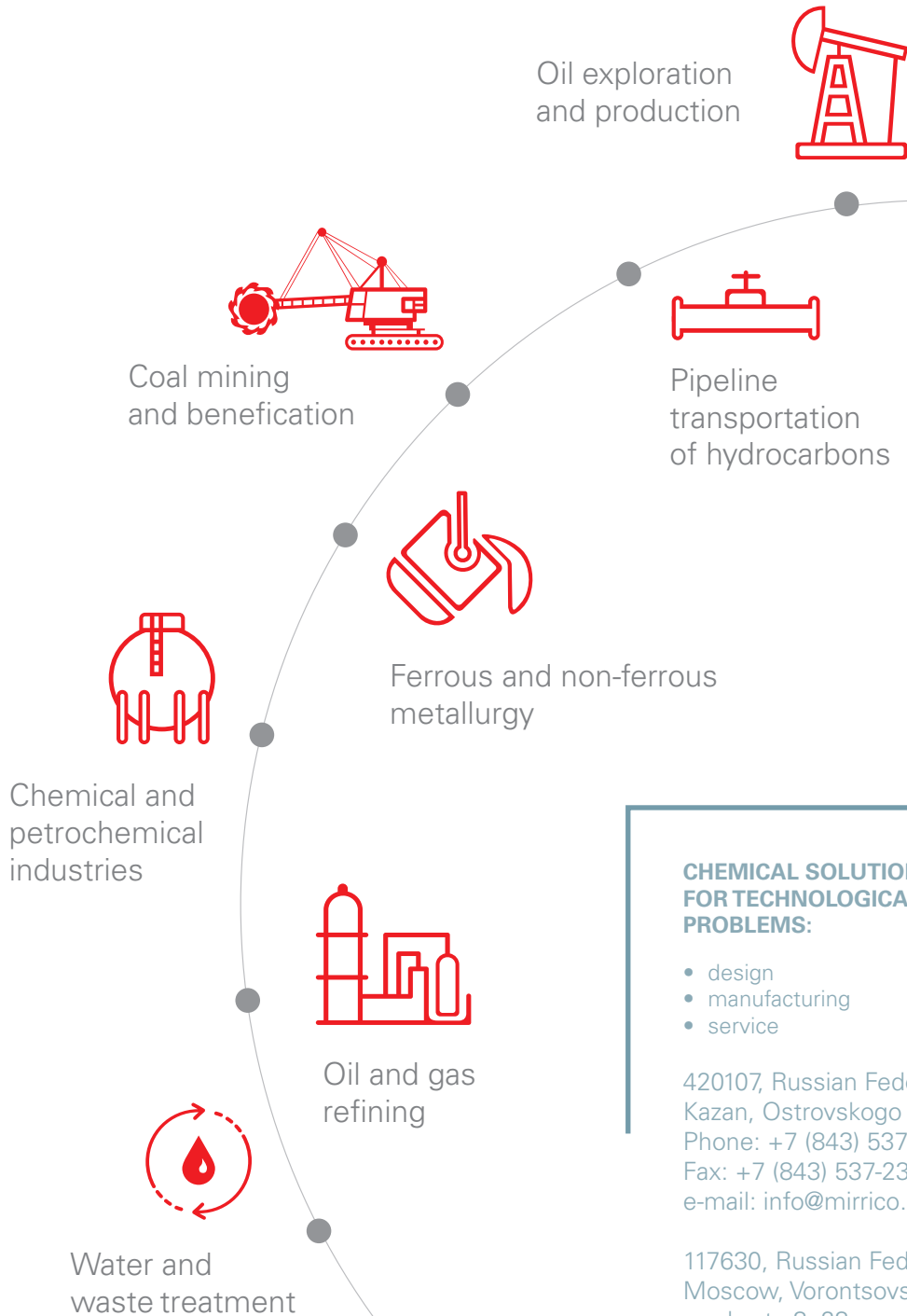

CHEMICAL SOLUTIONS FOR TECHNOLOGICAL PROBLEMS:

- design
- manufacturing
- service

420107, Russian Federation,
Kazan, Ostrovskogo st., 84
Phone: +7 (843) 537-23-93,
Fax: +7 (843) 537-23-94
e-mail: info@mirrico.com

117630, Russian Federation,
Moscow, Vorontsovskiy
prudy st., 3, 23
Phone: +7 (495) 663-16-35

